



Keep Working

**WIRE**

**RAFC209**

**ROLLO ALAMBRE FLUX CORED (AUTOPROTEGIDO) E71T-GS AWS A5.20**  
**FLUX CORED (SELF-SHIELDED) WIRE SPOOL E71T-GS AWS A5.20**



**FLUX CORED FCAW**



**0.9MM (0.035")**

DIÁMETRO ALAMBRE

**0.9KG**

PESO

**SELF SHIELDED**  
 ALAMBRE AUTOPROTEGIDO

**DCEN - Conecte el electrodo al terminal negativo**

**Soldadura de penetración profunda**

**Alambre/electrodo E71T**



POSICIONES DE SOLDADURA

Uniones de filetes

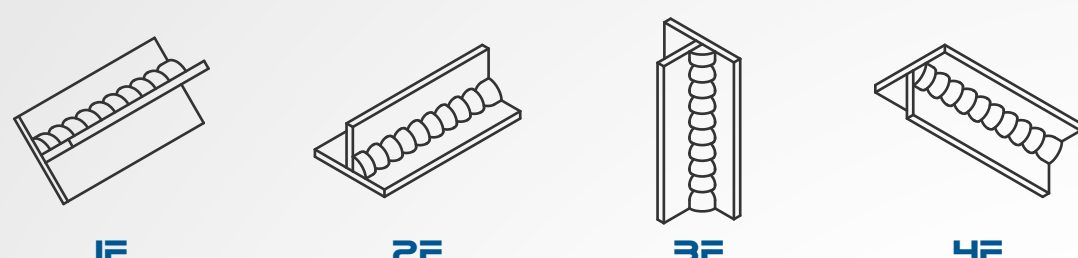

Uniones biseladas

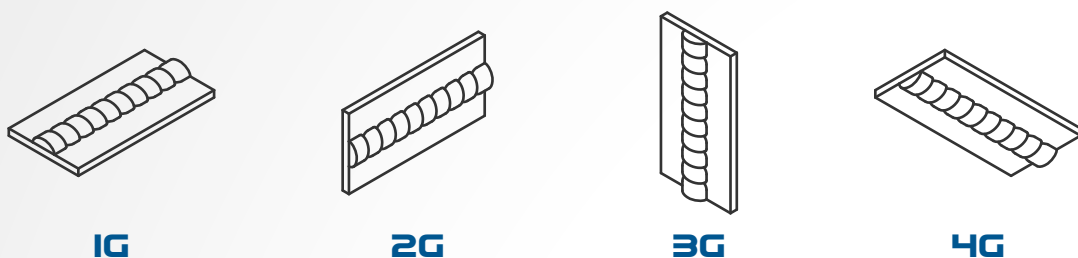

Uniones de tuberías

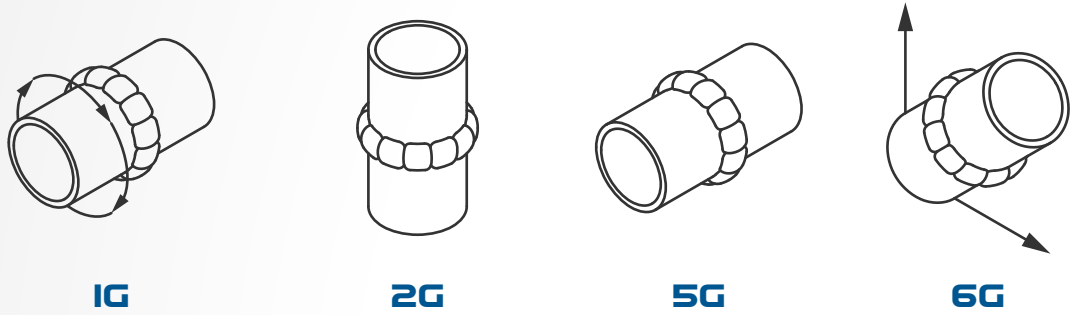

ÁNGULO DE VIAJE

**Halando**  
Penetración máxima

**Vertical**

**Empujando**  
Penetración mínima

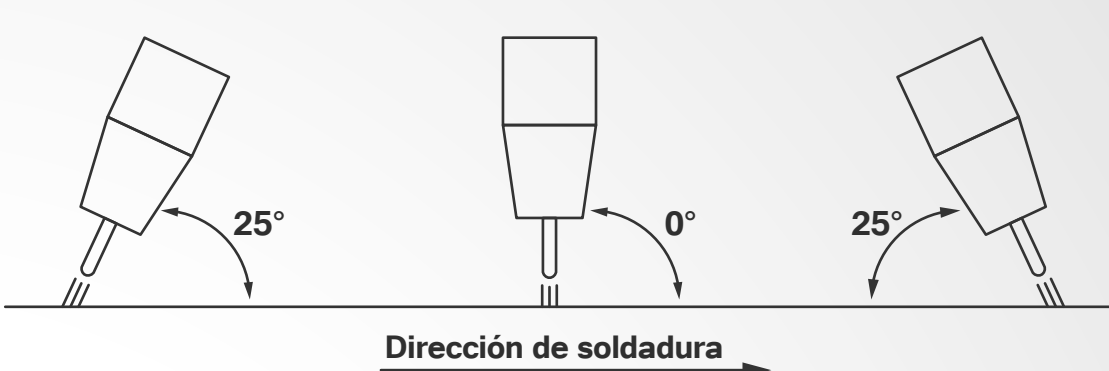

TIPO DE RODILLO

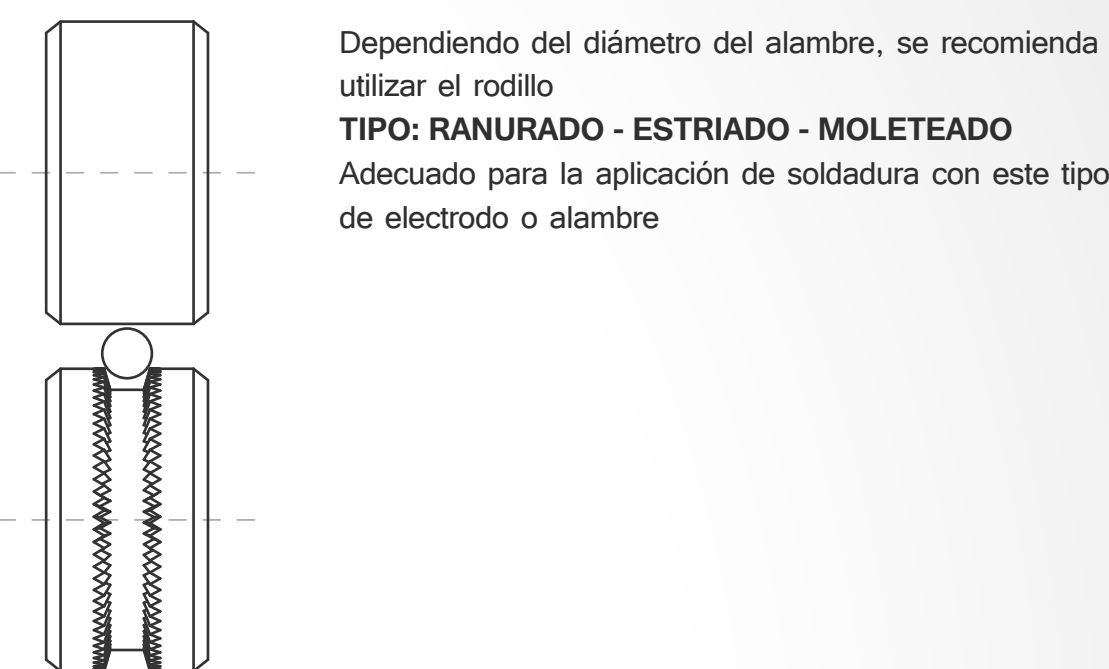

Dependiendo del diámetro del alambre, se recomienda utilizar el rodillo  
**TIPO: RANURADO - ESTRIADO - MOLETEADO**  
 Adecuado para la aplicación de soldadura con este tipo de electrodo o alambre

DATOS TÉCNICOS

<b>Diámetro carrete</b> Reel diameter	10mm
<b>Calibre alambre</b> wire gauge	0.9mm (0.035")

<b>Peso</b> Weight	0.9 Kg
<b>Normativa</b> Normative	E71T-GS AWS A5.20

MEDIDAS CAJA INDIVIDUAL

LARGO	ANCHO	ALTO	PESO
10.5 cm	5.0 cm	10.5 cm	1.1 Kg

MASTER BOX x 20und

LARGO	ANCHO	ALTO	PESO
27.0 cm	23.0 cm	23.0 cm	21.0 Kg

CONOCE MÁS  
LEARN MORE



KEEP WORKING

www.elitetools.co

