



Keep Working



RAFC208

ROLLO ALAMBRE FLUX CORED (AUTOPROTEGIDO) E71T-GS AWS A5.20
FLUX CORED (SELF-SHIELDED) WIRE SPOOL E71T-GS AWS A5.20



FLUX CORED FCAW



0.8MM (0.030")

DIÁMETRO ALAMBRE



0.9KG

PESO

SELF SHIELDED
 ALAMBRE AUTOPROTEGIDO

DCEN - Conecte el electrodo al terminal negativo

Soldadura de penetración profunda

Alambre/electrodo E71T



POSICIONES DE SOLDADURA

Uniones de filetes

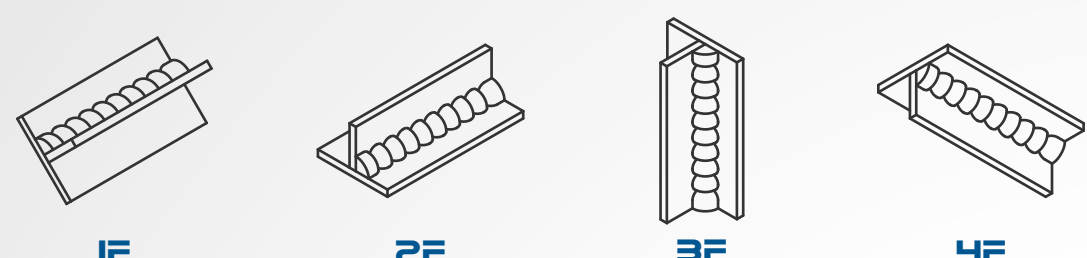

Uniones biseladas

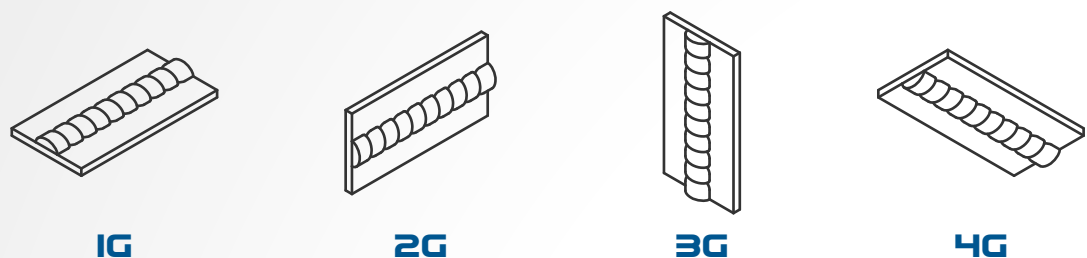

Uniones de tuberías

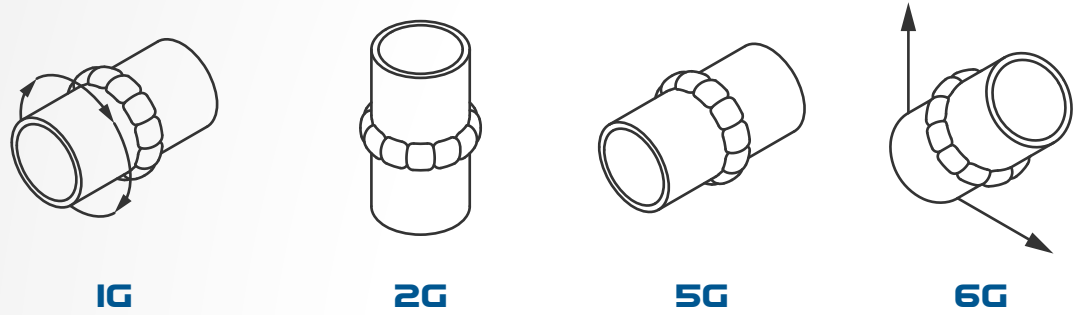

ÁNGULO DE VIAJE

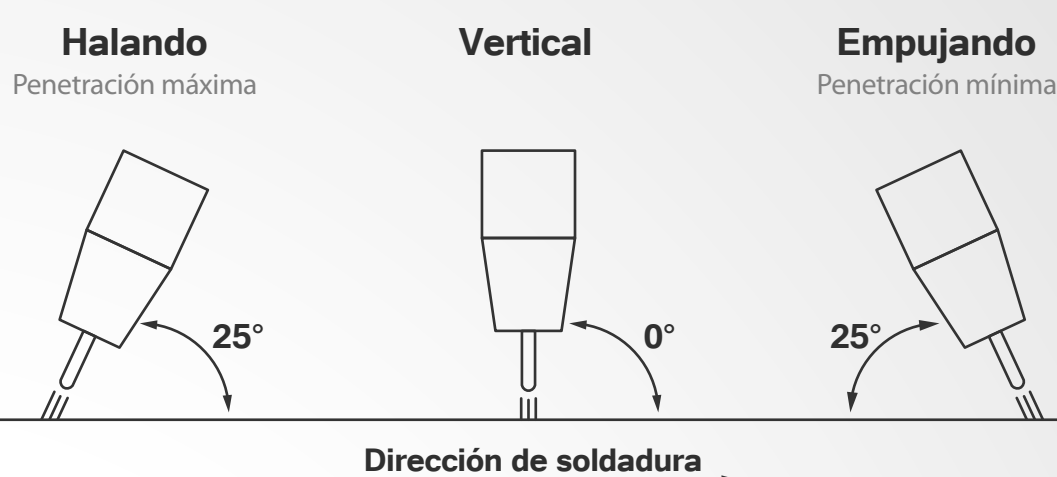

TIPO DE RODILLO

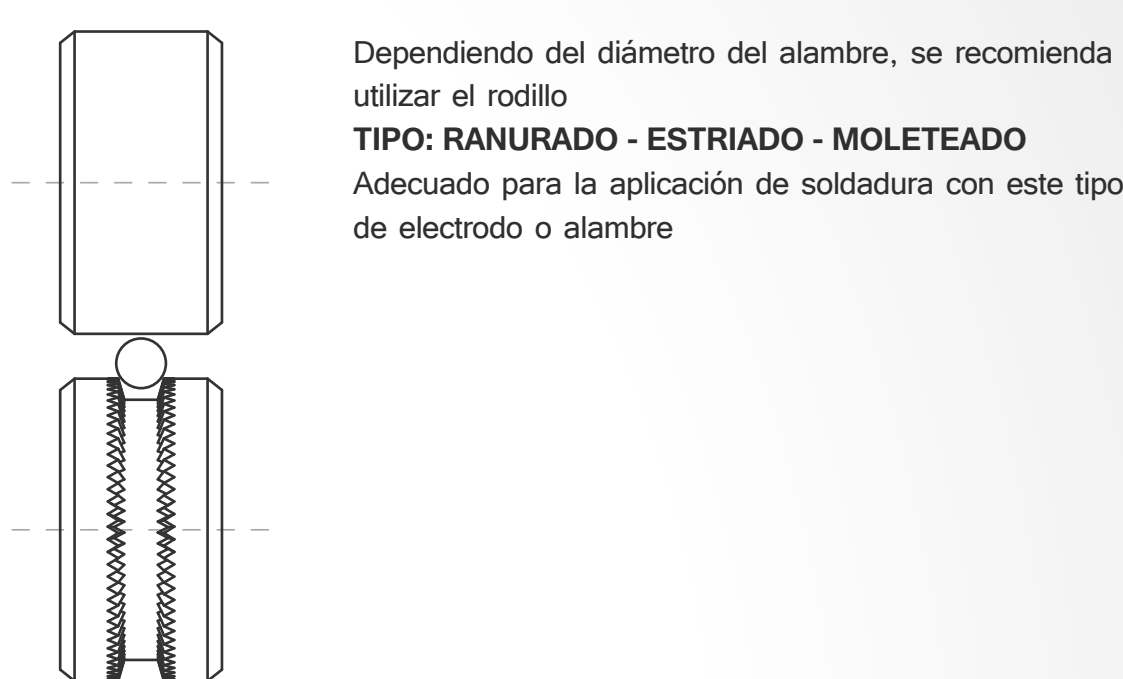

Dependiendo del diámetro del alambre, se recomienda utilizar el rodillo
TIPO: RANURADO - ESTRIADO - MOLETEADO
 Adecuado para la aplicación de soldadura con este tipo de electrodo o alambre

DATOS TÉCNICOS

Diámetro carrete Reel diameter	100mm
Calibre alambre wire gauge	0.8mm (0.030")

Peso Weight	0.9 Kg
Normativa Normative	E71T-GS AWS A5.20

MEDIDAS CAJA INDIVIDUAL



LARGO	ANCHO	ALTO	PESO
10.5 cm	5.0 cm	10.5 cm	1.1 Kg

MASTER BOX x 20und



LARGO	ANCHO	ALTO	PESO
27.0 cm	23.0 cm	23.0 cm	21.0 Kg

CONOCE MÁS
LEARN MORE

